

Technical Specification

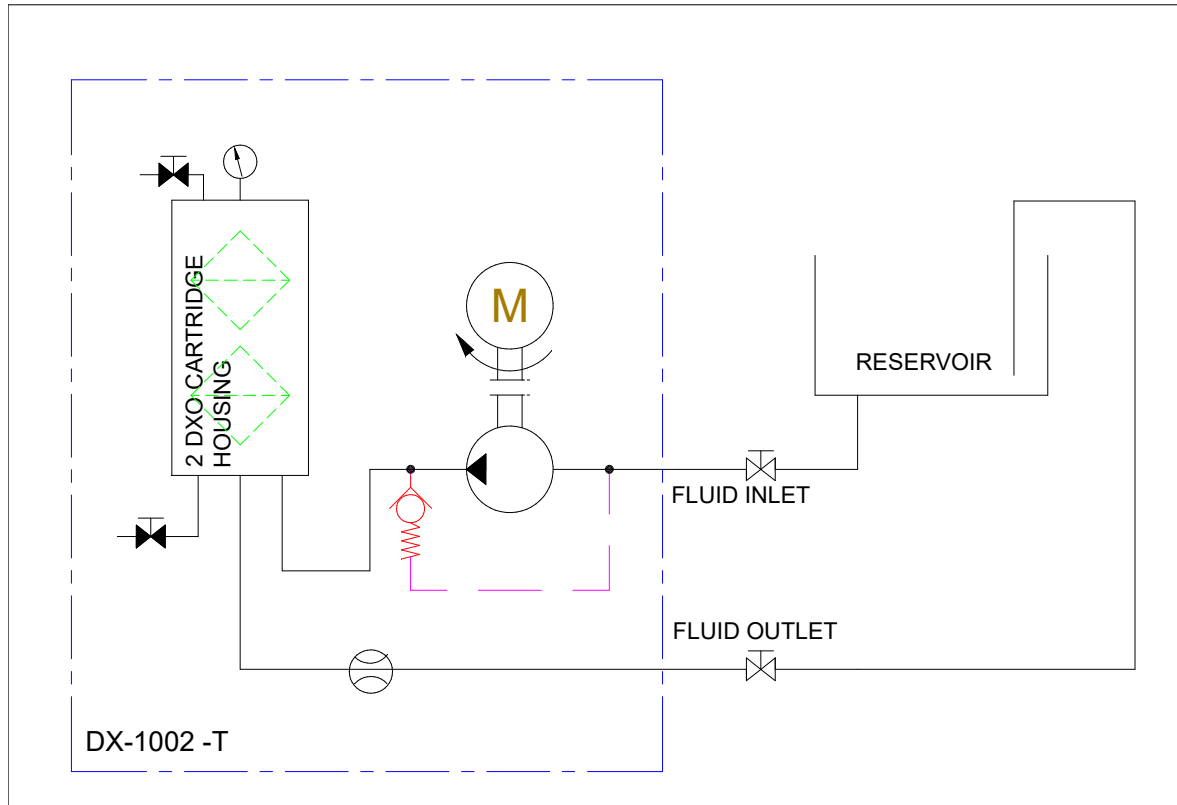

DX1002-T

AC Power	0,25KW, 110, 220-480 VAC, 50/60Hz
Pump Connection Ports	3/8" BSP In & Out
Sight Glass	Yes
Hydraulic Oil Volume Capacity	6000 Litres @ 32cSt
Typical Flow	2 Lpm ISOVG32 @ 20°C
Micron Rating	0,1 Micron
Weight[kgs]	22,9
Measure [mm]	H 984 x D 261 x L 437
Material	SS316
DXO Cartridge	x 2



General Arrangement

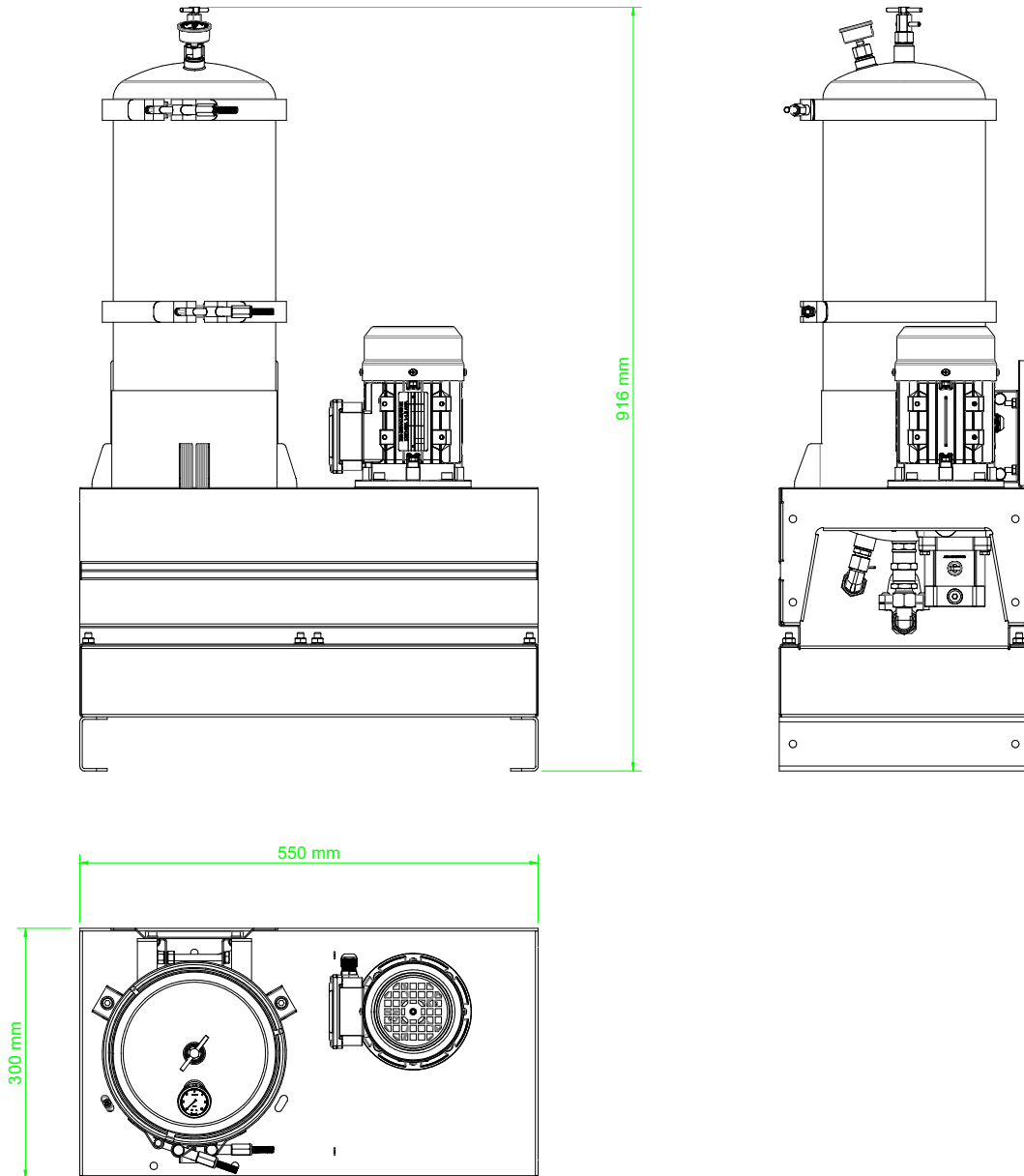

Model Code Selector

Model Code Selector

Series **A** **B** **C** **D** **E** **F** **G** **H** **I** **J** **K** **L** - **NNN**
 DX 10 02 - T G - - - - - 1 - (Special Execution On Request)

A Configuration

1	1 x Single Canister - 1 x DX Cartridge
2	1 x Single Canister + 1 x Dual Extender - 2 x DX Cartridge
3	1 x Single Canister + 1 x Triple Extender - 3 x DX Cartridge
4	2 x Single Canister + 2 x Dual Extenders - 4 x DX Cartridge
6	2 x Single Canister + 2 x Triple Extender - 6 x DX Cartridge
9	3 x Single Canister + 3 x Triple Extender - 9 x DX Cartridge
12	4 x Single Canister + 4 x Triple Extender - 12 x DX Cartridge

B Mounting

T	Backplate/Tray
---	----------------

C Insert

G	Green
---	-------

D Feed Type

Configuration	1-6	A	110v
		B	220v
		C	415v
	9,12	D	110v
		E	220v
		F	415v
		H	Hydraulic
1-6	P	Pneumatic	
	9,12	Q	Pneumatic
		N	None

E Frequency

1	50 Hz
2	60 Hz
N	Not Applicable

F Flow Indicator

V	Visual Indication	
D	Digital Indication	*
C	Both	*
N	None	

G Electrical Start/Stop Control Panel

1	Yes
N	None

H Overspill Sensor

1	Yes
N	None

I Condition Monitoring

1	Tan Delta	*
2	Particle Counter	*
3	Both	*
N	None	

J Interconnection Type

1	Pipework - SS
---	---------------

K Certification

1	Standard
2	Atex Zone 1
3	Atex Zone 2

L Painting

(Motor and Pump Only)	
N	None
P	Yes

* Only available in conjunction with Option G1

All information contained in this publication is indicative only and may be subject to change without prior notice.

