

DX1003-W

The DX modular housing arrangement offers a flexible and space conscious solution to integrating our innovative DXO Cartridge to both new and existing systems. We provide up to 12 cartridges as a single unit in a compact and easily maintainable layout.

The unit can be supplied with a number of standard options to provide an effective conditioning and monitoring package to suit the majority of systems. The flexibility of the unit allows tailoring to a customer's specific requirements.



DXO Cartridge

Dirt capacity:	1955 g, 0.1 micron
Water absorption, free and bound:	M 2600ml
Material insert:	Cellulose, Polypropylene



Technical Specification

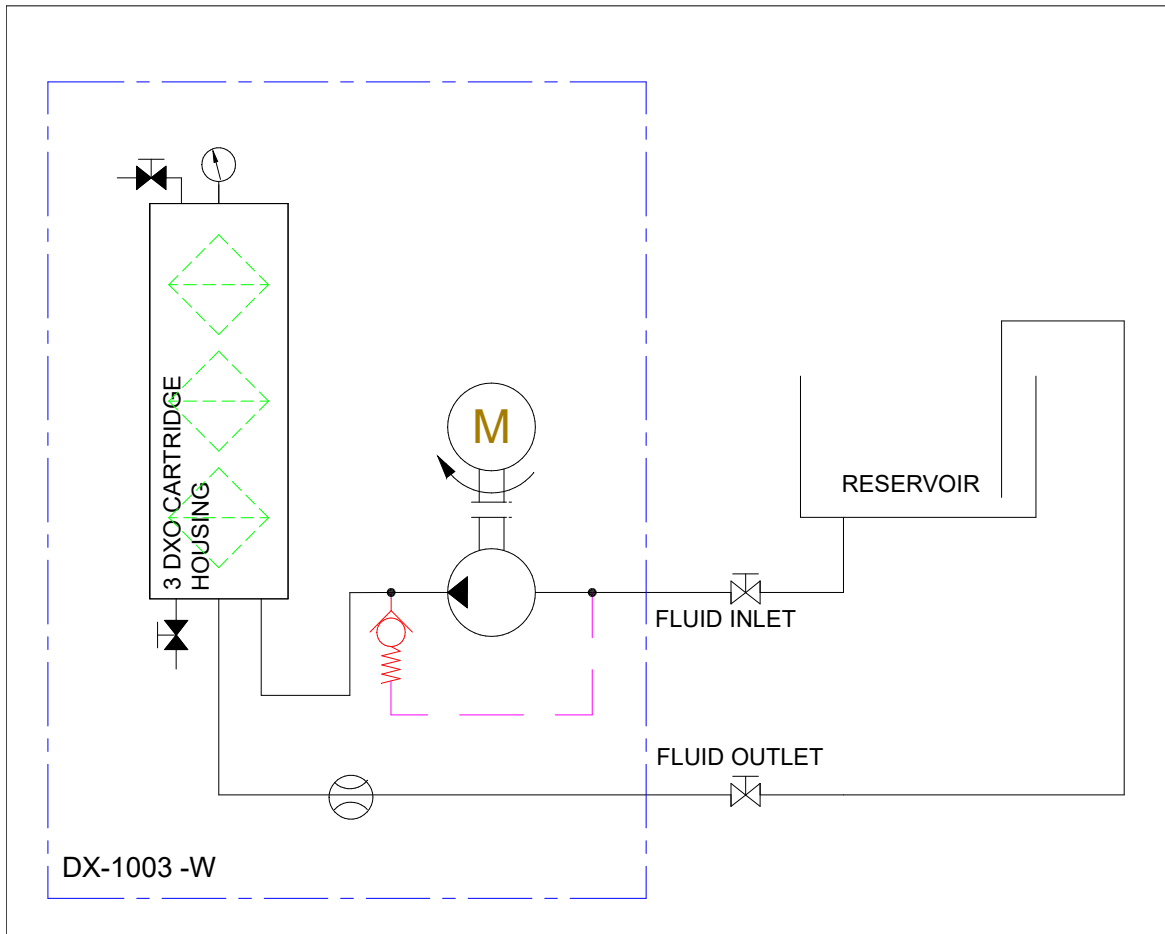

DX1003-W

AC Power	0,25-0,37KW,110, 220-480 VAC, 50/60Hz
Pump Connection Ports	3/8" BSP In & Out
Sight Glass	Yes
Hydraulic Oil Volume Capacity	9000 Litres @ 32cSt
Typical Flow	3 Lpm @ ISOVG32
Micron Rating	0,1 Micron
Weight[kgs]	26,7
Measure [mm]	H 984 x D 261 x L 437
Material	SS316
DXO Cartridge	x 3



General Arrangement

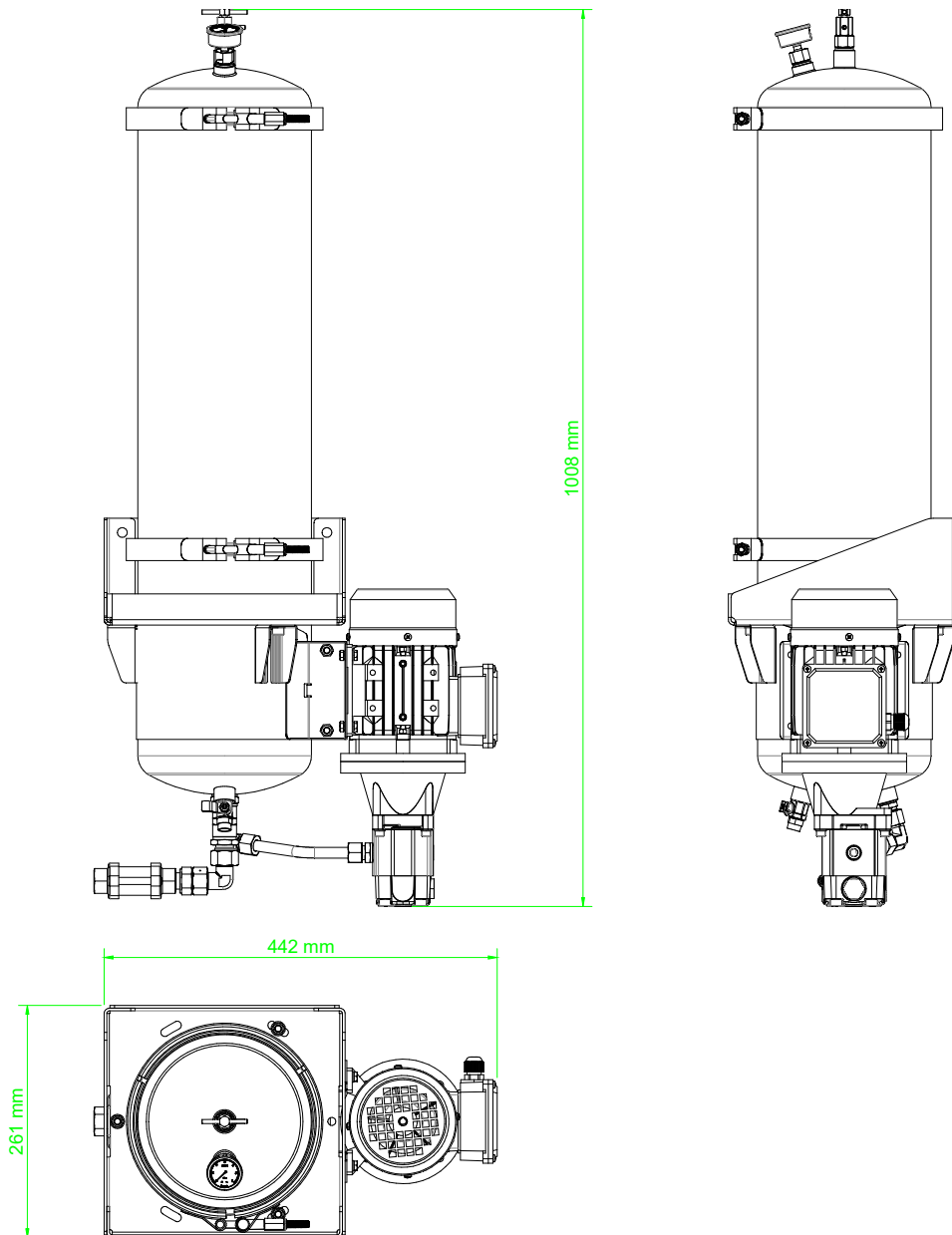

Model Code Selector

Model Code Selector

Series **A** **B** **C** **D** **E** **F** **G** **H** **I** **J** **L** **K** - **NNN**
DX **10** **03** - **W** **G** - - - **N** **1** - **NNN**
 (Special Execution On Request)

A Configuration

1	1 x Single Canister - 1 x DX Cartridge
2	1 x Single Canister + 1 x Dual Extender - 2 x DX Cartridge
3	1 x Single Canister + 1 x Triple Extender - 3 x DX Cartridge
4	2 x Single Canister + 2 x Dual Extenders - 4 x DX Cartridge
6	2 x Single Canister + 2 x Triple Extender - 6 x DX Cartridge
9	3 x Single Canister + 3 x Triple Extender - 9 x DX Cartridge
12	4 x Single Canister + 4 x Triple Extender - 12 x DX Cartridge

B Mounting

W	Wall Mount Bracket
---	--------------------

C Insert

G	Green
---	-------

D Feed Type

Configuration	1-6	A	110v
		B	220v
		C	415v
	9,12	D	110v
		E	220v
		F	415v
1-6	H	Hydraulic	
	P	Pneumatic	
	9,12	Q	Pneumatic
		N	None

E Frequency

1	50 Hz
2	60 Hz
N	Not Applicable

F Flow Indicator

V	Visual Indication
D	Digital Indication
C	Both
N	None

G Electrical Start/Stop Control Panel

1	Yes
N	None

H Overspill Sensor

N	None
---	------

I Condition Monitoring

1	Tan Delta
2	Particle Counter
3	Both
N	None

J Interconnection Type

1	Pipework - SS
---	---------------

K Certification

1	Standard
2	Atex Zone 1
3	Atex Zone 2

L Painting

(Motor and Pump Only)	
N	None
P	Yes

* Only available in conjunction with Option G1

