

DX1003TP - Luftdrevet Oljereenseunit

Pneumatisk drevet oljekondisjoneringsenhet

Et nytt modulært filterhus arrangement gir fleksible og plassbevisste løsninger for å integrere DXO patron-element til både nye og eksisterende system. Vi kan supplere fra 1 opp til 12 patron-element som en unit i et kompakt og plassbesparende oppsett. Dette gjør rensesystemet skalertbart fra smått til stort

Den luftdrevne oljekondisjoneringsuniten kan utstyres med en rekke standard alternativer som gir en effektiv behandlingspakke. Kan tilpasses de fleste oljesystemer. Løsningen er modul og fleksibel for å tillate kundespesifikke løsninger og krav. Vi har nå roterende luftdrevet motor med pumpe på våre uniter noe som forbedrer levetid.



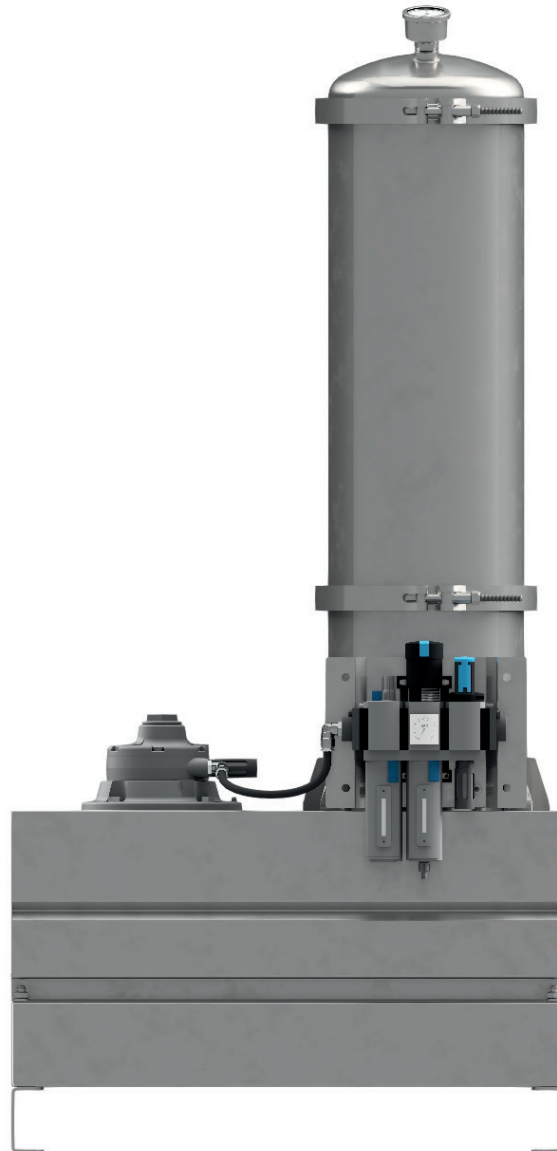

Air Motor	Pneumatic driven vane motor, EX class: II 2 GDc T4 (+10 °C < Ta < +40 °C
Max. Pressure [Barg]	Fluid Pressure 7 barg max /Air supply 7 Barg max
Pump & Connection Ports	Fluid cleaning side: 3/8"BSP In & Out. Air Regulator, drive supply: G1/4"BSP
Sight Glass	Yes
Hydraulic Oil Volume Capacity	9000 litre@ 32cSt
Typical Flow	3 Lpm @ ISOVG32
Purify Properties	Particles 0,1 Micron, Varnish, Bacterias, Water
Weight [Kgs]	33
Measure [mm]	H 1140 x D 369 x L 550
Material [non vetted parts]	SS316
DXO Cartridge	x3

Schematic view of the pneumatic driven unit

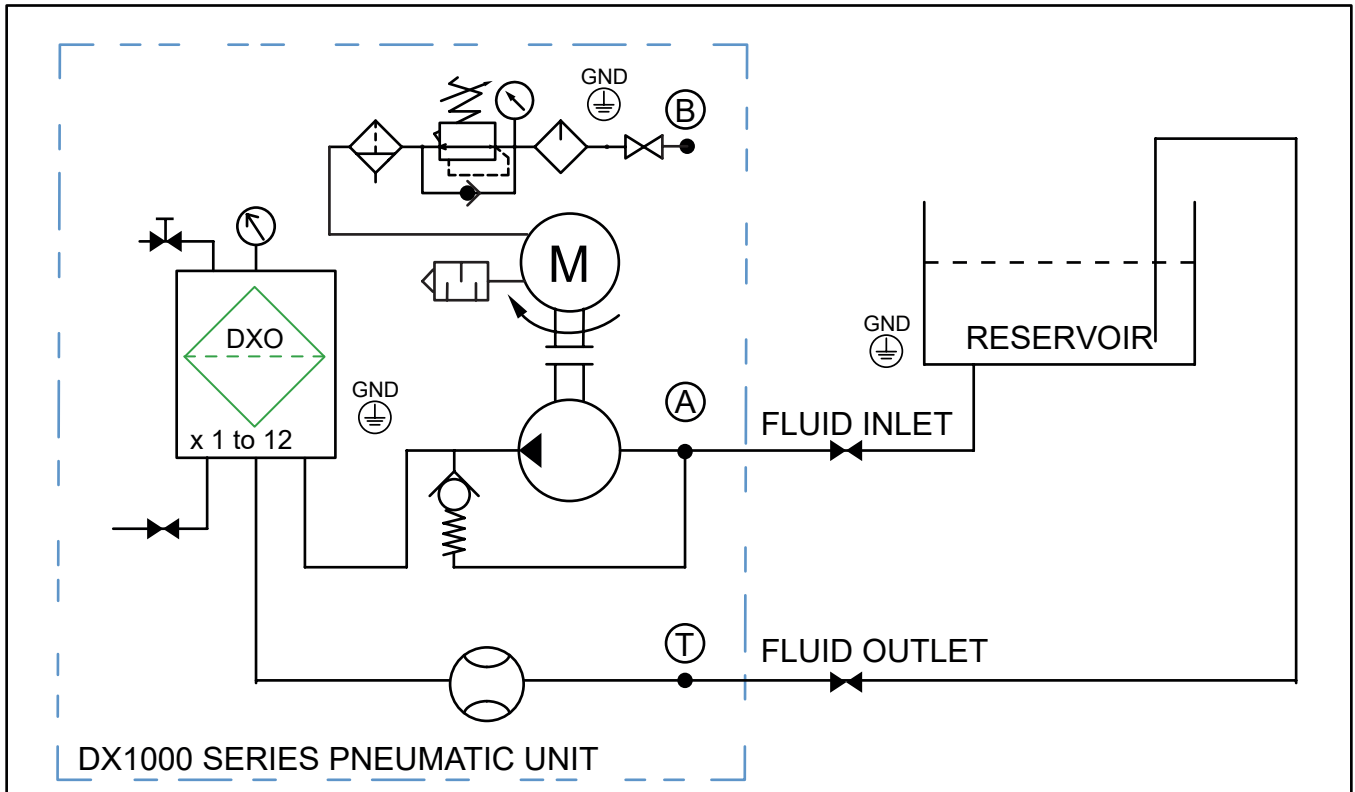

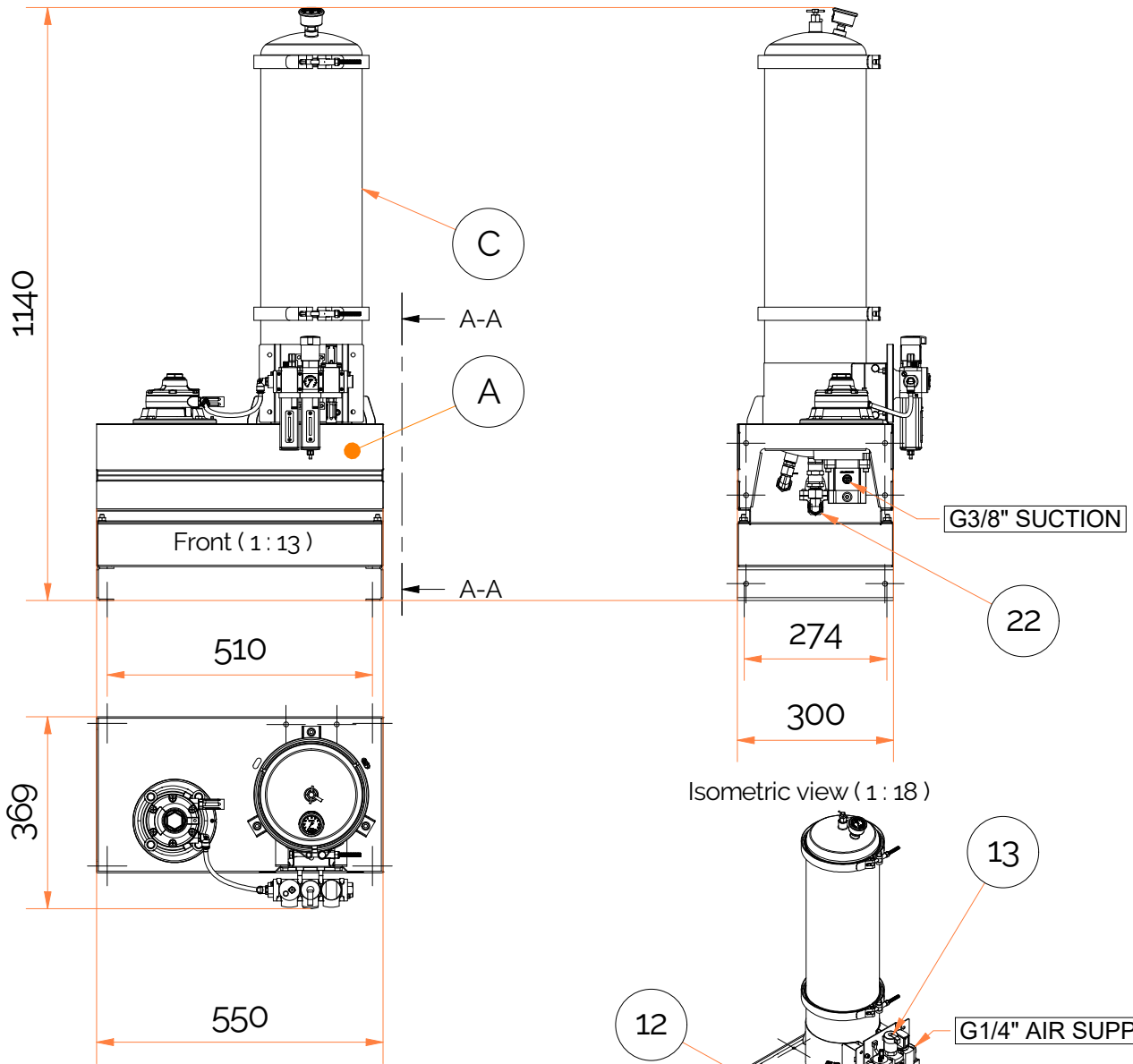

DX1000 Series, Triple oil cleaner
 Normal working oil pressure 0.8 to 6 bar
 Max. Oil pressure 7 Barg
 Design pressure 14 Barg
Removes:
 -Particles to 0.1 micron
 -Water
 -Oxidation bi-products (Sludge & resin)
 -Mitigates varnish deposits

PARTS LIST

ITEM	QTY	PART NUMBER	DESCRIPTION	MATERIAL
1	1	T	DX1000 SERIES, MODULE BASED EXTENSION ASSEMBLY FOR SINGLE DOUBLE & TRIPLE STACKED INSERTS	SS316L
A	1	DX1003TP-NVNNN11P	TRIPLE INSERT AIRDRIVEN OIL CLEANER, 0.1 MIC.	SS316L
B	1	PG10SS	10 BAR PRESSURE GAUGE	SS316L
C	1	DX1003	TRIPLE FILTERHOUSING FOR STACKABLE CARTRIDGE ELEMENTS. MAX. PRESSURE, 7 BARG. DESIGN PRESSURE 14 BARG.	SS316L
12	1	2AM-ARVg2	Air driven vane motor & pump, Area Class: II 2 GDc +1 C Ta +40	Fe Painted
13	1	531029	Air regulator for vane motor, MSB4-AGB_C4_J11_M2-WP-EX4-Z. Ex rated with lubricator, shut off valve	Several
22	1	VIS-BSP	DISCHARGE FORM FILTERUNIT, FLOW INDICATOR G3/8" BSPF ALTERNATIVE G1/2"	SS316

Designed by ME	Checked by	Approved by	Date	Date 11.04.2019
--------------------------	------------	-------------	------	---------------------------



AIR DRIVEN TRIPLE OIL CLEANER

DX1003TPNVNNN11P

Edition
A2019 Sheet
1 / 1