

DX1001W UNIT CONFIG;
DX1001WGBNV1NN11N
SINGLE PHASED 220-250VAC
MITIGATES VARNISH
REMOVES FROM HYD./LUB OIL:
HARD AND SOFT CONTAMINANTS
WEAR DEBRIS
WATER
BACTERIAS

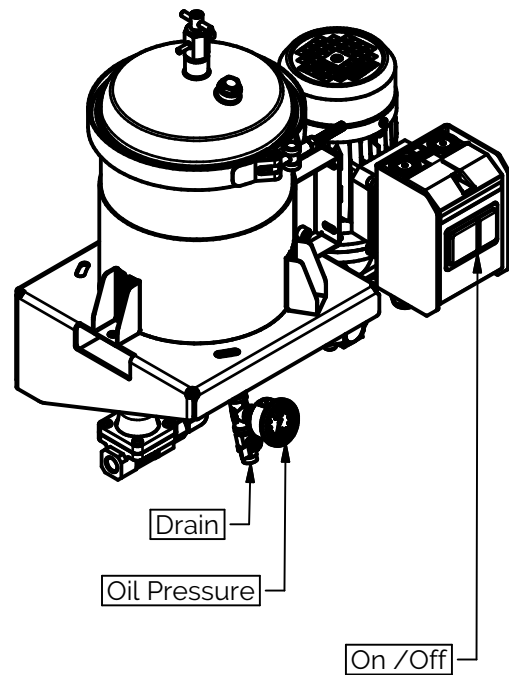

Designed by Delta-Xero Ltd	Checked by	Approved by	Date	Date 26.07.2019	18 KGS
			DX1001W OIL CLEANER UNIT		
			DX1001WGBNV1NN11N	Edition A26.07.2019	Sheet 1 / 1